

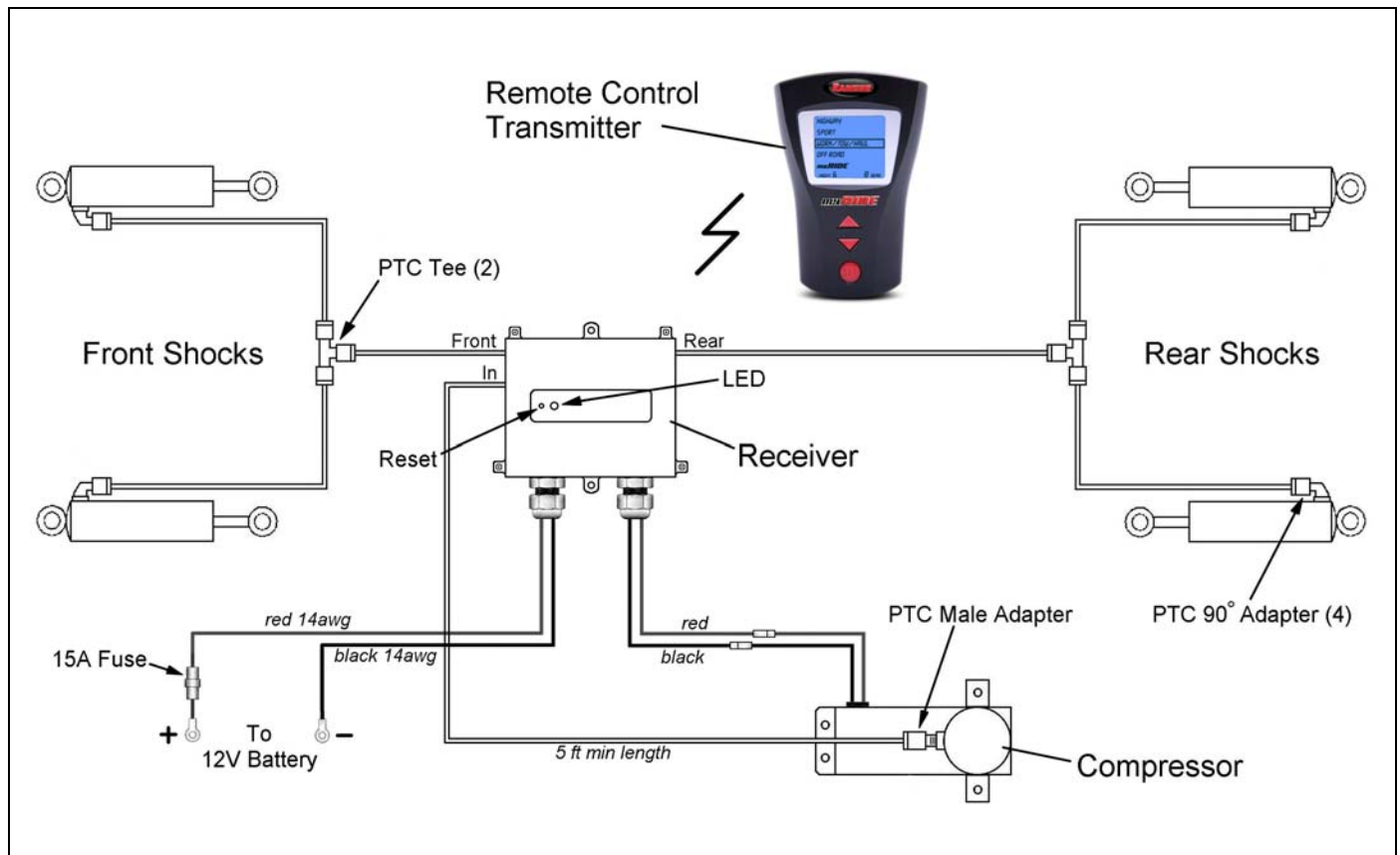

WIRELESS TUNING SYSTEM

READ INSTRUCTION THOROUGHLY FROM START TO FINISH BEFORE BEGINNING INSTALLATION

RS999705 Assembly Diagram



Parts List

P/N	Description	Qty.	P/N	Description	Qty.
96111	Tire Wrap Kit	1	96382	Compressor Kit	1
	Black Tie Wrap	30	96351	Compressor Assembly	1
96364	Shock Adapter Kit	1	96366	Mounting Hardware	1
96303	Push-to-connect 90° Adapter	4	DNX18003	Tubing Cutter	1
	O-ring	4	96383	Airline Tubing, 70 ft.	1
	Gasket	4	96390	Receiver/Transmitter Kit	1
96381	Hardware Kit	1	96387	Remote Control Transmitter	1
96301	Push-To-Connect Tee	2	96388	Receiver	1
96386	Push-To-Connect male Adapter	1	96389	AAA Batteries, 3 Pack	1
	15 Amp Fuse	1	96399	Instructions	1
	Allen Wrench	1	96399-1	Quick Start Up Guide	1
	10-24 x 1.25 HHSTS	6			

IMPORTANT NOTES:

- A. Refer to your owner's manual for proper vehicle lifting techniques. Never work under a vehicle that is not supported by jack stands.
- B. The receiver and air compressor can be mounted in other locations besides the engine compartment. Choose a high and dry location that best fits your application. If extra wire is needed, splice 14awg only. The compressor can also be mounted in any position but should be located near the receiver.
- C. Route all wires and airlines away from hot or sharp objects. Do not allow airline to kink, bind or make contact with moving components. Turn the wheels completely left and right to verify clearance. Inspect the airlines before and after lowering the vehicle to the ground.
- D. Dipping the end of the airline in clean motor oil before insertion will improve the seal. **The airline must be inserted 9/16" for the shock adapter and 1/2" for the tee and male adapter.** Cut airline on white marks (9/16" apart) to help with the insertion depth. Push-to-connect fittings will "click" when the airline is fully inserted. See Illustration 1.

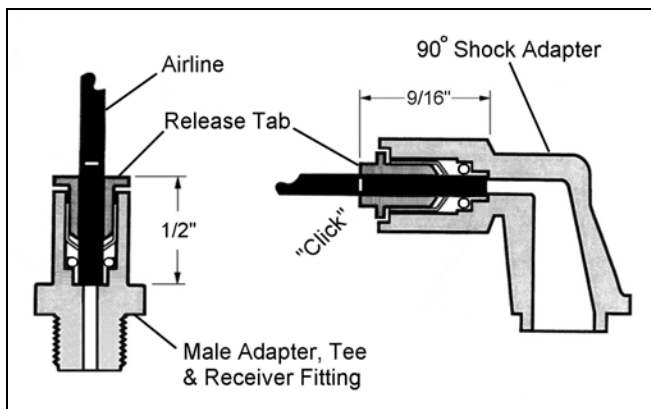

Illus. 1

- E. To remove the airline, deflate system (zero settings), push down on quick release tab and pull line. Trim airline 9/16" with supplied tube cutter before reinstalling. Do not remove airline while system is pressurized.

INSTALLATION:

1. Turn the adjuster knob on each RS9000X shock to position 1. Remove the adjuster assemblies with the supplied allen wrench. Save screws for reuse. Remove any gasket material left on the shocks.
2. Install gasket and slide o-ring on 90° shock adapter. See illustration 2. Coat the o-ring with oil or lithium grease.
3. Using the supplied allen wrench, carefully attach the adapter assembly to the shock with the original screws. Tighten screws evenly. **Do not over tighten.**

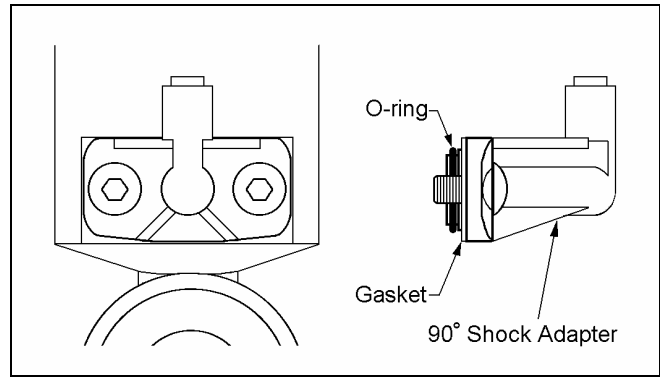

Illus. 2

4. Repeat steps 1 through 3 to install the rest of the 90° adapters.
 5. Thread PTC male adapter into compressor outlet. **Do not over tighten.**
 6. Pick a location inside the engine compartment to mount the receiver and compressor, usually on the same side as the vehicle battery. Refer to Important Note B.
 7. Using the receiver and compressor as templates, mark and center punch the mounting hole locations. Drill the appropriate hole at each location.
 8. Attach the receiver and compressor with the supplied self-tapping screws and/or machine screws. Use rubber isolators on the compressor to reduce vibration.
 9. Connect the electrical wires from the compressor to the matching wires on the receiver. Refer to assembly diagram. Do not connect battery wires at this time.
 10. To connect the front shock absorbers together, measure and cut two pieces of airline with the supplied tube cutter. Fully insert an airline into each shock adapter and connect the airlines with a push-to-connect (PTC) tee. Refer to assembly diagram and Important Notes. Secure airline with tie wraps.
- NOTE:** Before cutting the airline, add an additional 6 to 8 inches to allow for suspension movement. Cuts must be clean and square, use the supplied tube cutter only.
11. Repeat step 10 to connect the rear shocks together.
 12. Measure and cut airline to connect the front and rear shocks to the receiver. Refer to assembly diagram. Secure airline with tie wraps.
 13. Cut 5 feet of airline. Coil the airline (if necessary) and connect the compressor to the receiver supply inlet.
 14. Attach the red wire from the receiver to the positive battery post. Attach the black wire to the negative battery post.
 15. Push set button to activate. Follow operating instructions.

OPERATION:

If display is blank, push set button to activate.

To adjust shock absorbers to a preset setting:

- Push the up or down arrow until the desired preset is selected.
- Push set button once to accept. The selection flashes as system adjusts to the preset. When flashing stops, adjustment is complete.

To adjust shock absorbers to a custom setting:

- Push the down arrow until *myRIDE* is selected.
- Push set button once to select the front shocks.
- Push up arrow to increase control or down arrow to decrease control.
- Once the desired ride control is reached, push set button to accept.
- Rear shocks are automatically selected.
- Push up arrow to increase control and down arrow to decrease control.
- Once the desired ride control is reached, push set button to accept. The selection flashes and system adjusts to the custom setting. When flashing stops, adjustment is complete.

If you notice an E on the front shock absorber setting, an error has occurred at the receiver module. Check receiver for a flashing amber light and follow the troubleshooting guide.

FCC REGULATION:

Changes or modifications not expressly approved by the party responsible for compliance could void the user's authority to operate the equipment.

This device complies with Part 15 of the FCC Rules.

Operation is subject to the following two conditions:

- (1) This device may not cause harmful interference
- (2) This device must accept any interference received, including interference that may cause undesired operation.

Rancho Industries U.S.A. Limited Warranty

RS999705 *myRIDE* Wireless Tuning System

The *myRIDE* wireless tuning system is limited to a 2-year, 24,000 mile warranty. Tenneco Automotive warrants each new *myRIDE* wireless tuning system against factory defects in material and workmanship (except for finish, including the shock boot) for the first to occur of 2 years or 24,000 miles after the date of purchase.

For more warranty information or technical assistance, visit our website at www.gorancho.com or call 1-734-384-7804.

To reorder a replacement Transmitter (RS96387) use part number RS999706.

To reorder a replacement Receiver (RS96388) use part number RS999707.



TROUBLESHOOTING GUIDE

Tool List

- Spray bottle containing a 20% soapy water solution
- Allen wrench (supplied with kit)
- Small container with 1 ounce of clean motor oil
- Flashlight
- Air line cutter (supplied with kit)
- Toothpick to push reset button

Troubleshooting Chart

Problem	Possible Source	Corrective Action
Transmitter display blank or hard to see	<ul style="list-style-type: none"> • Transmitter inactive-display timed out • Battery voltage low 	<ul style="list-style-type: none"> • Push set button • Replace batteries
Receiver not responding/compressor not operating	<ul style="list-style-type: none"> • Blown fuse at receiver • Poor electrical connection at bullet connectors or battery • Receiver shut down 	<ul style="list-style-type: none"> • Replace 15 amp fuse • Repair connection • Push reset button until flashing green light appears.
Transmitter displays an error "E" and receiver has a flashing amber light	<ul style="list-style-type: none"> • Major air leak and compressor operated continuously for more than 30 seconds 	<ul style="list-style-type: none"> • Fix major air Leak and follow operating procedures.
Frequent compressor operation because of a slow air leak NOTE: The receiver automatically monitors shock absorber settings and occasional compressor operation is normal.	<ul style="list-style-type: none"> • Airline not fully inserted/seated into shock adapter or push-to-connect fitting. • Misaligned or damaged o-ring on shock adapter. Refer to illustration 2 • Damaged airline end • Loose fitting at compressor outlet 	<ul style="list-style-type: none"> • Push airline into shock adapter 9/16". Push airline into male adapter, tee or receiver fitting 1/2". See Important Notes. • Reinstall or replace o-ring. Coat o-ring with oil or grease • Re-cut end of airline with supplied air line cutter. Dip end of airline in oil. Airline must be re-cut every time it is removed. • Tighten fitting. Do not over tighten

Slow Leak Detection

Pressurize system to nine. Spray air line connections and adapters with soapy water until the leak is found (escaping bubbles). See illustrations below. DO NOT SPRAY ELECTRICAL COMPONENTS. When leak is detected, release pressure (zero shock absorber setting) and follow corrective action.

